

AT41 LIMITED SPACE THERMOWELL



American Thermowell thermowells are used in demanding conditions of intense pressure and temperature, across a wide variety of industries.

Our limited space thermowells are designed and manufactured 100% in house, and are made to client specifications and they accept standard or custom-made thermometers, thermocouples, bulbs and RTD's.

Our limited space thermowells are also available in a wide variety of process thread sizes and configurations which include, but are not limited to, NPT, NPS, and BSPT.

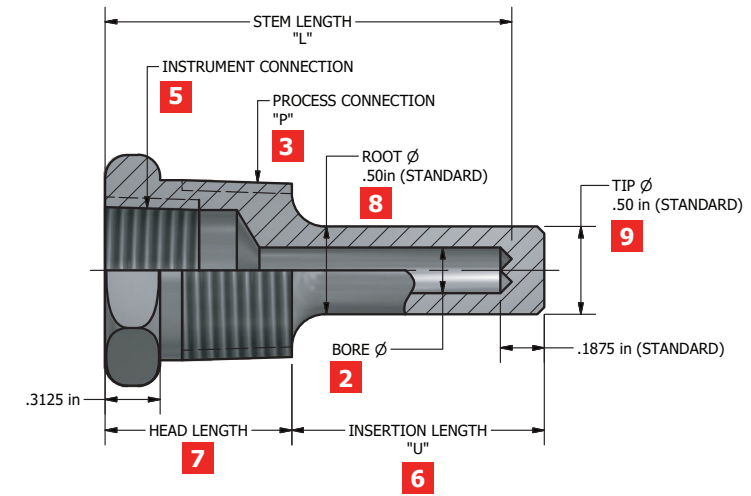

Please note: Various configurations may not be available. American Thermowell will notify you if you have selected a incompatible part combination.



1 Thermowell Stem Style	
Code	Description
AT41	Straight Stem

2 Bore Size	
Code	Description
A	0.260
B	0.385
C	0.515
D	0.203
E	0.375
F	0.390
G	0.343
M	0.406
N	0.280
O	0.302
P	0.312
R	0.275
U	0.394
V	0.354
X	0.437

3 Process Connection	
Code	Description
AA	1/2" NPT
AB	3/4" NPT
AC	1" NPT
AD	1-1/4" NPT
AE	1-1/2" NPT
AF	1/2" NPSM
AZ	1/2" ANPT
AR	1/4" NPT
AT	1/8" NPT
AG	1/2" BSPP
AH	3/4" BSPP
AI	1/2" BSPT
AJ	3/4" BSPT
AK	M14 x 1.5
AL	M18 x 1.5
AM	M20 x 1.5
AN	M24 x 1.5
AO	M27 x 2.0
AP	1/4" - 20 UNF
AQ	3/8" - 24 UNF
AU	1/2" - 20 UNF
AV	5/8" - 18 UNF
AW	3/4" - 16 UNF
AX	7/8" - 14 UNF
AY	1" - 14 UNF

4 Material	
Code	Description
L2	316/316L
H2	304/304L
H3	304H
K2	310/310H
L3	316H
J1	317
J3	317L
M2	321/H
M3	RA330
N2	347/H
N3	410
N4	446
N5	HR160
S3	904L
S4	AL-6XN
S2	Alloy 20
S1	Alloy 200
R1	Alloy 400
P1	Alloy 600
P3	Alloy 601
P2	Alloy 625
Q3	Alloy 800/H/HT
Q1	Alloy 825
U2	Alloy B2
U3	Alloy B3
U4	Alloy C-22

4 Material (Continued)	
Code	Description
U1	Alloy C-276
R2	Alloy K500
U5	Alloy X
C1	Aluminum 6061
A1	Brass
E4	Carbon Steel 1018
E3	Carbon Steel 12L14
E1	Carbon Steel ASTM A105
G1	Chrome-M-Moly F22
F1	Chrome-Moly-F11
F6	Chrome-Moly-F5
F7	Chrome-Moly-F9
F8	Chrome-Moly-F91
Y2	CPVC
F2	Duplex F51/2205
E2	Alloy 20
B1	Naval Brass
Y1	PVC
F4	Stainless F44/254 SMO
F3	Super Duplex F53/2507
F5	Super Duplex F55
W1	Teflon
T1	Alloy 825
T2	Tit Gr2
T3	Tit Gr5
Z1	Zirc 702

5 Instrument Connection	
Code	Description
AA	1/2" NPT
AB	3/4" NPT
AC	1" NPT
AD	1-1/4" NPT
AE	1-1/2" NPT
AF	1/2" NPSM
AS	1/2" NPT TO CSA
AZ	1/2" ANPT
AR	1/4" NPT
AT	1/8" NPT
AG	1/2" BSPP
AH	3/4" BSPP
AI	1/2" BSPT
AJ	3/4" BSPT
AK	M14 x 1.5
AL	M18 x 1.5
AM	M20 x 1.5
AN	M24 x 1.5
AO	M27 x 2.0
AP	1/4" - 20 UNF
AQ	3/8" - 24 UNF
AU	1/2" - 20 UNF
AV	5/8" - 18 UNF
AW	3/4" - 16 UNF
AX	7/8" - 14 UNF
AY	1" - 14 UNF

6 Insertion Length	
Code	Description
xxxx	Imperial: 6.500" = 06500 Metric: 165.1 mm = 01651
*U length =>100.000" or 10,000.0mm see sales person for custom part number	

7 Head Length	
Code	Description
xxxx	Imperial: 2.25" = 02250 Metric: 57.2 mm = 00572

8 Root Diameter	
Code	Description
xxxx	Imperial: 0.875" = 0875 Metric: 22.2 mm = 0222

9 Tip Diameter	
Code	Description
xxxx	Imperial: 0.500" = 0500 Metric: 12.7 mm = 0127

10 Measurement	
Code	Description
I	Imperial
M	Metric

Custom sizes, connections and materials may not be listed, contact American Thermowell today to find out more.

OPTIONS

- Brass Plug & Chain
- Stainless Plug & Chain
- Teflon Coating
- Stellite Overlay
- Kynar Coating
- Dye Penetrant Test
- Dye Penetrant Cap
- Dye Penetrant Root (Optional)
- Internal Hydrostatic Testing
- External Hydrostatic Testing
- Material Test Report (MTR)
- Nace MR0175
- PMI
- Tantalum Sheath (Flanged Only)
- Velocity Calculation per PTC 19.3 TW-2010
- X-Ray
- O2 Cleaning
- Post Weld Heat Treatment
- UT bore concentricity
- UT phased array
- CofC (Certificate of compliance)
- COO (certificate of origin)
- Traceability Index
- ITP (Inspection Test Plan)
- Stamping
- SS tags
- Visual dimensional report
- Electro polish
- Pickle and Passivation

American Thermowell has provided quality thermowells since 1991.



American Thermowell

4861 Paula Road, Kountze, Texas 77625
1-409-246-1111
sales@americanthermowell.com
www.americanthermowell.com



Specializing in instrumentation and process control hardware.

- Thermowells
- Orifice Plates
- Bleed & Flush Rings
- Valves



Revised (09/21/2022)